

More precise measurement of volume flow at swirl outlets with the **volume flow straightener testovent 417.**

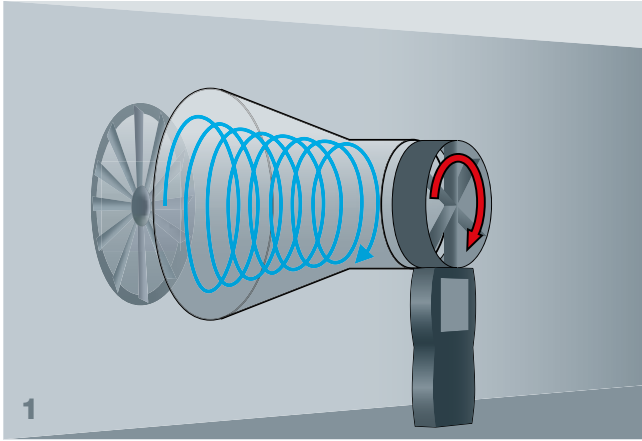

Among the factors affecting whether humans feel comfortable in a room is the air movement. The intensity with which this is perceived depends on the air outlets installed. Swirl outlets are of increasing significance, as the fresh air introduced into a room is diffused rather than direct. This reduces the mean air velocity, which increases the perceived comfort.

However, the flows and turbulences created at a swirl outlet make an exact measurement of the volume flow, and thus the correct adjustment of the ventilation system, difficult. The volume flow straightener testovent 417 solves this problem. The world innovation developed by Testo changes the swirl into an almost uniform air flow, thus ensuring a precise determination of the volume flow at swirl outlets.



1
Rotation direction of the swirl is identical to that of the vane – the measured air flow velocity is too high.

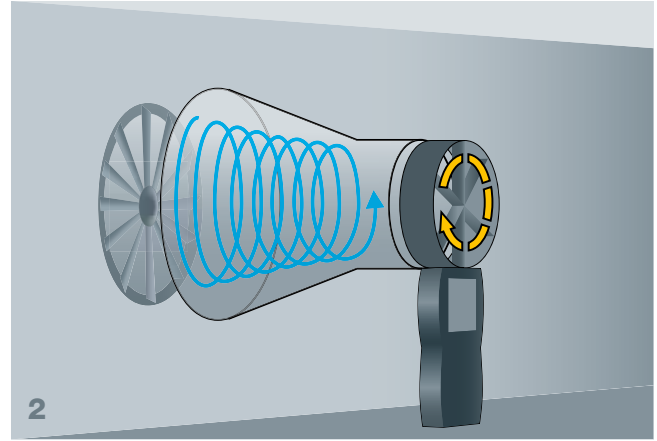

2
Rotation direction of the swirl is opposite to that of the vane – the measured air flow velocity is too low.

The challenge.

The right measurement of air flows and the correct determination of volume flow at ventilation outlets can be particularly demanding from a metrological point of view. Whereas active flow hoods usually provide more accurate measurement results, their handling is often inconvenient for quick spot measurements. In practice, vane anemometers and the corresponding funnels are often used instead. And as long as the air is flowing from the outlets straight into the room, that is not a problem.

However, this is often not the case, because for reasons of comfort, so-called swirl outlets are used. These are suitable for the fast exchange of a large volume of air, in small rooms as well as in large ones. This type of outlet is often used in buildings in which a high level of indoor air flow is required, e.g. in office buildings, schools, recreation rooms, hospitals or private homes. The typical feature of these ventilation outlets is that the input air does not flow straight into the room. Instead, the air flow is diverted in such a way that a continuous diffusion swirl is created. This allows the supply air and the air already present in the room to be mixed better. As a consequence, the mean air velocity in the room decreases. Those present in the room generally perceive this as more pleasant.

For the measurement of volume flow, however, swirl outlets present a problem, because the swirl influences the rotation of the vane in the measuring instrument used, in different ways, as you can see in the illustrations 1 and 2.

In both cases, the swirl leads to a measurement error: The volume flow is displayed as either too high (1) or too low (2). The ventilation system is then either incorrectly adjusted down (1.) or up (2.). As a consequence, this means either too little fresh air in the room (1.) or a ventilation system running under an unnecessary high load (2.).

The solution.

The patent-pending volume flow straightener testovent 417 subdues the swirling air flow coming out of the swirl outlet, and changes it into an almost uniform flow. The influence of the swirl on the rotation of the vane decreases, and the volume flow can be measured quickly, easily and reliably – for example with the vane anemometer testo 417.

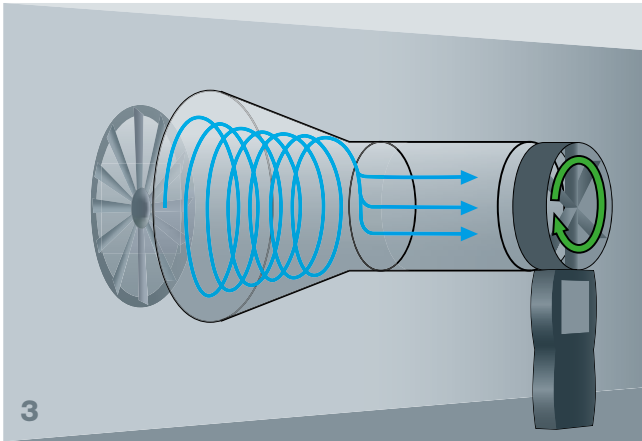

The volume flow straightener testovent 417 subdues the swirl, ensuring more precise measurement results.

The volume flow straightener testovent 417 is installed between the measurement funnel and the vane probe. In its interior is a specially developed honeycomb structure which ensures that the swirl is interrupted and converted into an almost uniform flow. This allows up to 50 % more precise volume flow measurements at swirl outlets.

However, the volume flow straightener is a passive system, and cannot compensate pressure loss – a certain measurement inaccuracy must therefore always be taken into account. This is, however, considerably reduced in comparison to other passive measurement methods.

This allows the volume flow straightener testovent 417 on the one hand to save costs and energy thanks to more efficiently adjusted ventilation systems, and on the other hand to control an important factor for thermal comfort reliably and better.

The volume flow straightener testovent 417 can only be used in combination with a funnel (funnel set testovent 417) and a measuring instrument. The following options are available as measuring instruments:

- Vane anemometer testo 417
- Reference measuring instrument testo 480 in combination with a 100 mm vane probe
- Multi-function measuring instrument testo 435 in combination with a 100 mm vane probe



Measuring instrument, e.g. testo 417.



Volume flow straightener testovent 417.



Funnel for plate outlets with \varnothing 200 mm.



Funnel for ventilation outlets 330 x 330 mm.



Volume flow straightener testovent 417 – all advantages at a glance:

- More precise measurement of volume flow, independently of swirl direction
- Retrofittable for existing funnel sets from Testo
- More efficient adjustment of ventilation systems

More information.

More information and answers to all your questions concerning volume flow measurement at swirl outlets at www.testo.com.